



HYDRA-SIEVE

Designed for efficient and optimum solid / liquid separation.
Custom built to your requirements, just specify the flow rate and particulate exclusion size.
One position, parabolic shaped, one piece screen.
Available as single or double units.

INDUSTRIAL APPLICATIONS

- Wine production
- Fish processing
- Meat processing & slaughterhouse
- Pulp & paper
- Pharmaceutical refining
- Fruit & vegetable canning
- Dairy & brewery
- plus many others....

Creative process engineers | Original equipment manufacturers

8a Trugood Drive, East Tamaki, Auckland 2013 | PO Box 58844 Botany, Manukau 2163 | P 09 274 0049 | www.engex.nz

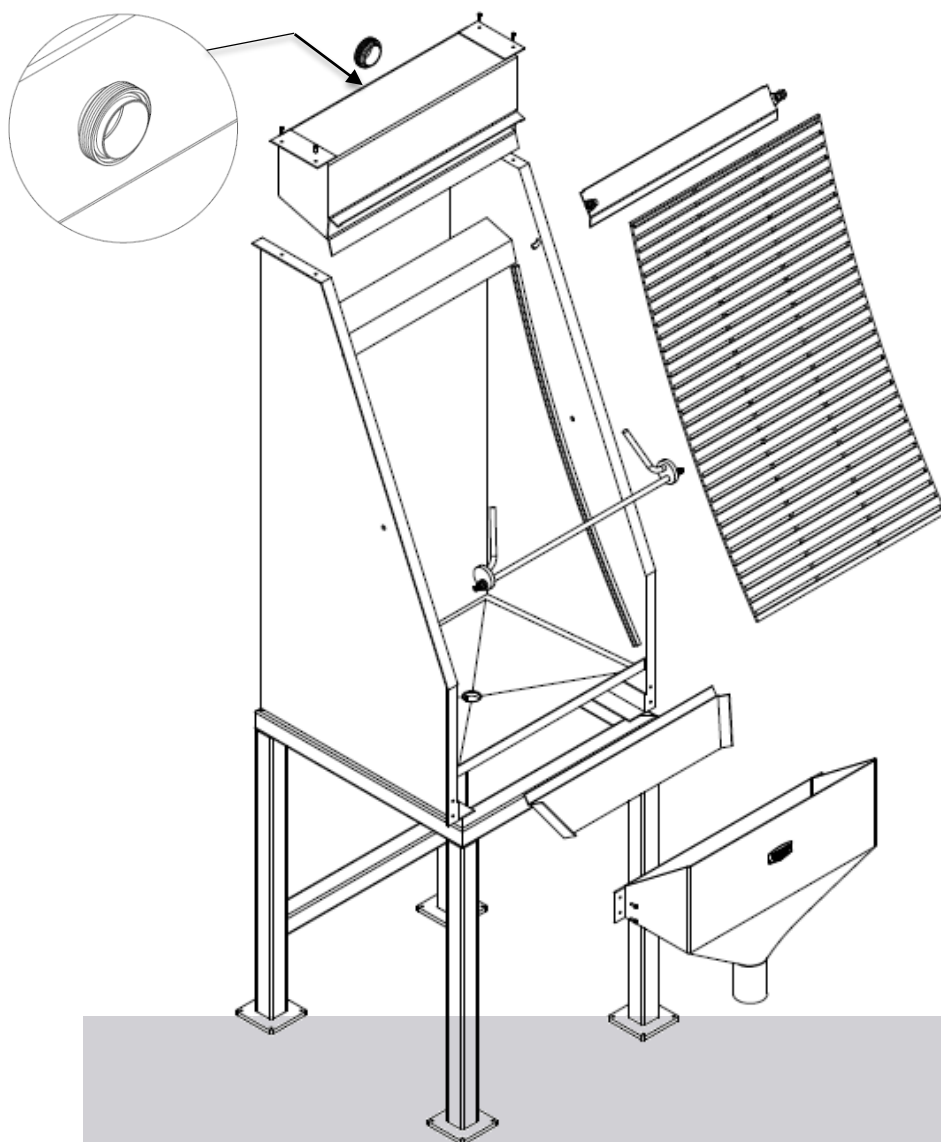

FEATURES

- Robust construction
- Sanitary & simple design for easy cleaning
- No moving parts - no maintenance
- Removable feed box
- Removable particulates collector
- Any connection to retentate outlet
- Single or double units available
- 304 or 316 stainless steel frame
- Lockable heavy duty castor wheels for easy maneuverability
- Screens made from specially formed, puncture proof 316L stainless steel wires.
- Additional screen storage space on skid base

TECHNICAL DATA

Standard model	H1
Frame size	1520mm (w) x 1990mm (h) x 610mm (d)
Screen size	600mm x 992mm
Wire size	3mm x 4.6mm
Slot sizes	2.0mm, 1.0mm, 0.5mm or 0.25mm
Outlet connection	2" RJT (retentate)

Creative process engineers | Original equipment manufacturers